

# Borderlites

BL-2012

Architectural Lighting  
Patio/Gazebo Lighting  
Flood Lighting  
Sign Lighting  
Recreational Lighting  
Stairway/Step Lighting

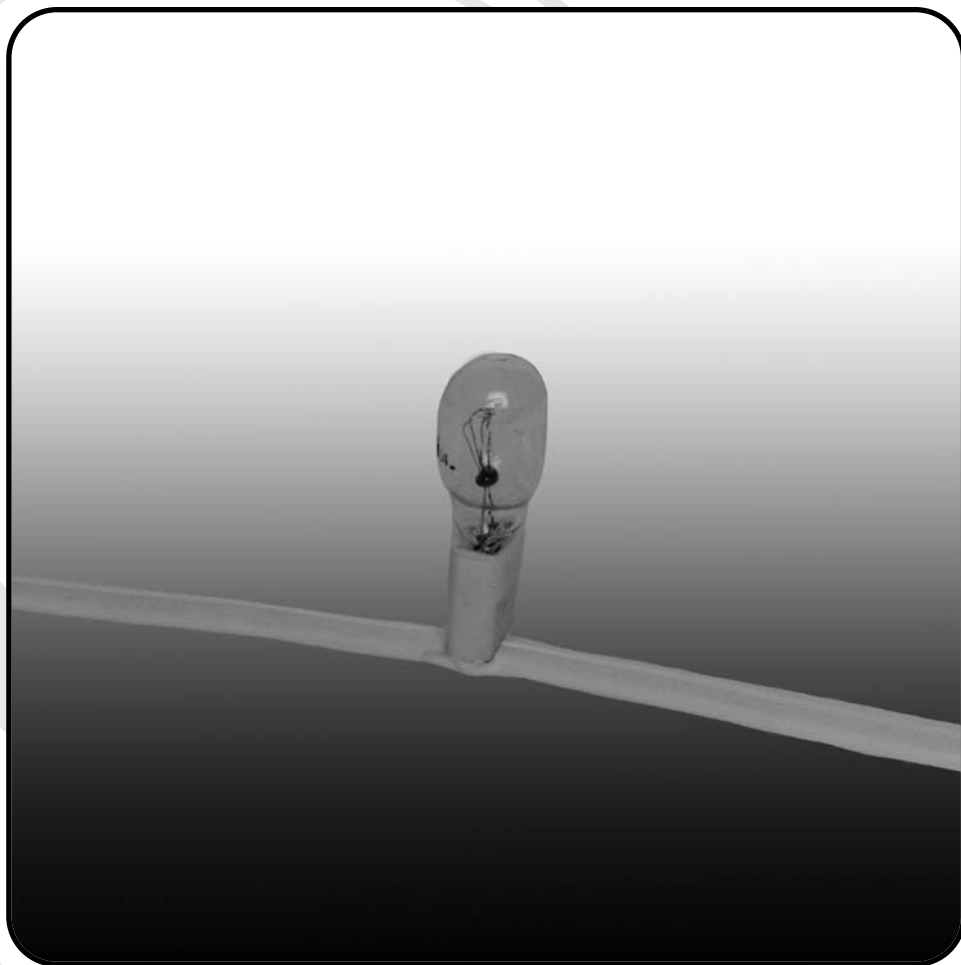

**Nightscaping®**  
1705 E. Colton Avenue  
Redlands, California 92374  
Tel: (909) 794-2121  
Fax: (909) 794-7292  
Help Line: (800) 544-4840  
E-mail: [info@nightscaping.com](mailto:info@nightscaping.com)  
<http://www.nightscaping.com>

Create a festive and upbeat atmosphere using commercial quality Borderlites by Nightscaping®. Borderlites utilize the largest lamps in the Nightscaping® string light family and are ideal for outlining commercial structures, roof lines, windows and columns. They are also appropriate for highlighting trees or structure along walkways, in parks, or other public and residential spaces.

**Lamp Standard** 20 Lamps (Standard)  
BL-2012-W -LO904 (Standard 7.5W - 150W total per string)

**Lamp Spacing:** 12" on Center

**Material: Wire:** #16-2 White (-W) Stranded.

**Sockets:** White Noryl™ with phosphor bronze weather-resistant contacts.

**Finish:** BL-2012 -W (Standard)  
BL-2012 -1 (Optional)

**Strand Length:** 20' of lamps, plus 5' of lead  
Custom lengths, lamp spacing available Call for quote.

**Socket:** Non-corroding Noryl™ (Wedge Base)

**Mounting:** Mount with 1/2" #T-25 staples directly to wood. Mount to trees with nursery tape.

*Nightscaping®*

# Borderlites

BL-2012



*Nightscaping*

**Optional:** 32' Section of lamps, Center Fed = 33 lamps/247.5W Total per string. (Option)

**Accessories:** **Clip:**  
AC-5050 Adhesive-backed Mini-Clip  
MB-605 1/2" String light Cable Mount Clip  
MB-610 1" String light Cable Mount Clip  
**Mini-Channel:**  
**5' Mini-Channel without Fascia. White is Standard.**  
EA-2012-1, -7, -W (Standard)  
EA-2012-2, -3, -4, -8, -9, -AV, -VP (Optional w/surcharge)  
**5' Mini-Channel with Fascia. White is Standard.**  
EA-2013-1, -7, -W (Standard)  
EA-2013-2, -3, -4, -8, -9, -AV, -VP (Optional w/surcharge)

**Warranty:** 10-year 'repair or replacement' warranty. \Repair de 10 o \warranty..

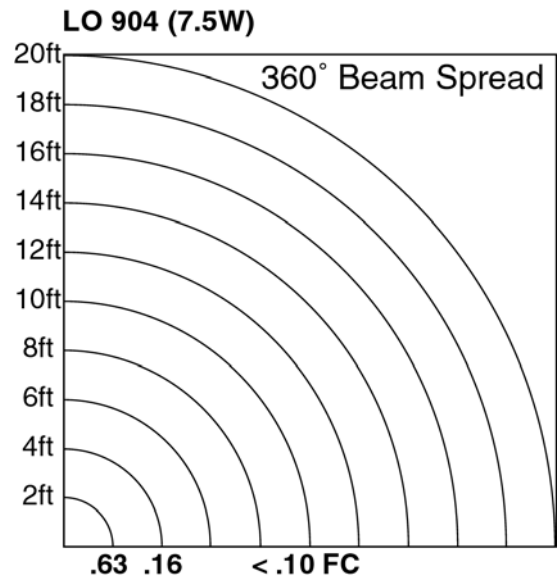
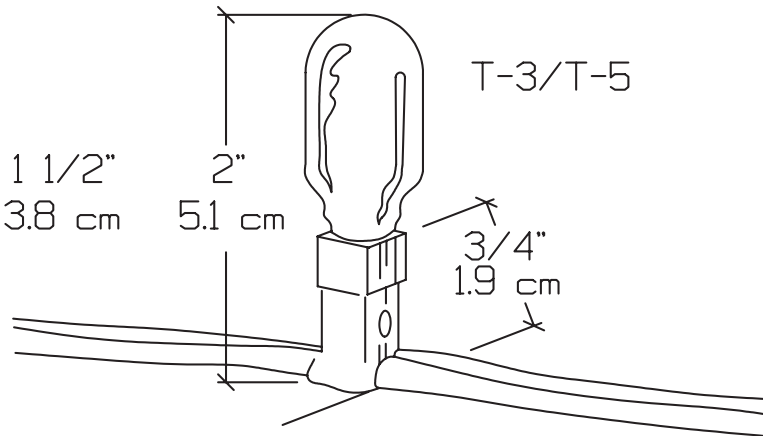

STANDARD LAMP PHOTOMETRIC

## DESIGN TIP\*

Use in either 20' standard sections (20 Lamps) or center fed 32' sections (32 lamps).